



D811521 00100_01 28-01-10

ЛИНЕЙНЫЙ ПРИВОД ДЛЯ РАСПАШНЫХ ВОРОТ

PHOBOS N
PHOBOS NL

РУКОВОДСТВО ПО УСТАНОВКЕ

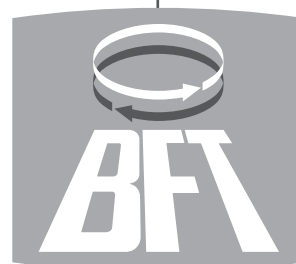
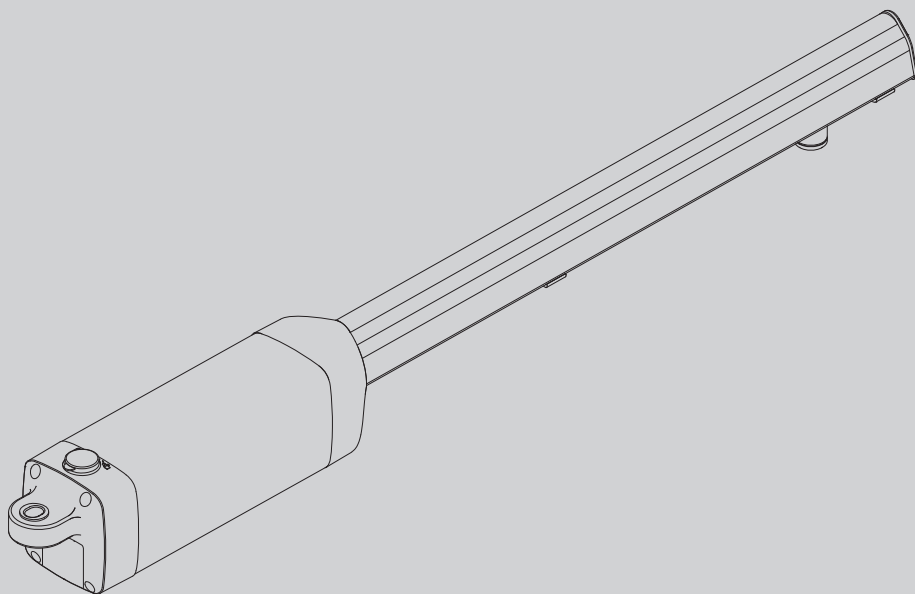

AZIENDA CON SISTEMA DI GESTIONE
INTEGRATO CERTIFICATO DA DNV
= UNI EN ISO 9001:2000 =
UNI EN ISO 14001:2004

Attenzione! Leggere attentamente le "Avvertenze" all'interno! **Caution!** Read "Warnings" inside carefully! **Attention!** Veuillez lire attentivement les Avertissements qui se trouvent à l'intérieur! **Achtung!** Bitte lesen Sie aufmerksam die „Hinweise“ im Inneren! **¡Atención!** Leer atentamente las "Advertencias" en el interior! **Let op!** Lees de "Waarschuwingen" tigre aan de binnenkant zorgvuldig!

Fabbricante / Manufacturer / Fabricant / Hersteller / Fabricante / Fabrikant / Fabricante/ Κατασκευαστής / Producent / Изготовитель / výrobce / Üretici:

BFT S.p.a.

Indirizzo / Address / Adresse / Adresse / Dirección / Adres / Endereço / Διεύθυνση / Adres / Адрес / Adresa / Adres:

Via Lago di Vico 44
36015 - Schio
VICENZA - ITALY

Dichiara sotto la propria responsabilità che il prodotto: / Declares under its own responsibility that the following product: / Déclare sous sa propre responsabilité que le produit: / Erklärt auf eigene Verantwortung, daß das Produkt: / Declara, bajo su propia responsabilidad, que el producto: / Verklaart onder haar verantwoordelijkheid dat het product / Declara, sob a sua responsabilidade, que o produto / Δηλώνει υπεύθυνα ότι το προϊόν / Oświadcza na własną odpowiedzialność, że produkt / Заявляет под свою ответственность, что изделие / Prohlašuje na vlastní odpovědnost, že výrobek / Kendi sorumluluğu altında aşağıdaki ürünü:

Motoriduttore per cancelli a battente mod. / Gearmotor for swing gates mod. / Motoréducteur pour portails battants mod. / Getriebemotor für Drehtore Modell / Motorreductor para cancelas con batiente mod. / Reductiemotor voor vleugelpoorten model / Motoredutor para portões de batente mod. / Ηλεκτρομειωτήρας για ανοιγόμενες καγκελόπορτες μοντέλο / Silnik z reduktorem do bram skrzydłowych model / Редукторный двигатель для створчатых ворот модель / Převodový motor pro brány s křídly model / ...modeli kanatlı bahçe giriş kapıları için motor redüktörü

PHOBOS N, PHOBOS NL, PHOBOS N BT, PHOBOS NL BT

È costruito per essere incorporato in un macchinario che verrà identificato come macchina ai sensi della DIRETTIVA MACCHINE. / Has been produced to be incorporated into a machinery, which will be identified as a machine according to the MACHINERY DIRECTIVE. / A été construit pour l'incorporation successive dans un équipement qui sera identifié comme machine conformément à la DIRECTIVE MACHINES. / Dafür konstruiert wurde, in ein Gerät eingebaut zu werden, das als Maschine im Sinne der MASCHINEN-DIREKTIVE identifiziert wird. / Ha sido construido para ser incorporado en una maquinaria, que se identificará como máquina de conformidad con la DIRECTIVA MAQUINAS. / Gebouwd is om deel uit te maken van een inrichting die wordt geïdentificeerd als machine volgens de MACHINERICHTLIJN. / Foi construído para ser incorporado numa maquinaria, que será identificada como máquina em conformidade com a DIRECTIVA MÁQUINAS / Έχει κατασκευαστεί για να ενσωματωθεί σε ένα μηχάνημα που θα προσδιοριστεί ως μηχάνημα σύμφωνα με την ΟΔΗΓΙΑ ΜΗΧΑΝΗΜΑΤΩΝ / Został wyprodukowany z przeznaczeniem do montażu w urządzeniu, które zostanie określone jako maszyna w myśl DYREKTYWY MASZYNOWEJ / Изготовлен для встраивания в оборудование, которое будет определено как «машина» в соответствии с ДИРЕКТИВОЙ ПО МАШИНАМ / Je vyroben pro montáž do strojního zařízení, které bude označeno jako stroj podle SMĚRNICE O STROJNÍCH ZAŘÍZENÍCH. / MAKINE DİREKTİFİ'nin hükümleri uyarınca makine olarak tanimlanacak bir makine grubuna entegre edilmek için üretilmiş oldugu / È conforme ai requisiti essenziali di sicurezza delle Direttive: / It also complies with the main safety requirements of the following Directives: / Est conforme aux exigences essentielles de sécurité des Directives: / Es entspricht den grundlegenden Sicherheitsbedingungen der Direktiven: / Es conforme a los requisitos esenciales de seguridad de las Directivas: / Conform is met de fundamentele veiligheidsvereisten van de volgende Richtlijnen / Está conforme aos requisitos essenciais de segurança das Directivas / Συμμορφούται στις βασικές απαιτήσεις ασφαλείας των Οδηγιών / Jest zgodny z podstawowymi wymogami bezpieczeństwa Dyrektyw / Соответствует основным требованиям по безопасности Директив / Vyhovuje hlavním bezpečnostním požadavkům směrnice / Aşağıdaki direktiflerin temel güvenlik şartlarına uygun oldugu beyan eder.

BASSA TENSIONE / LOW VOLTAGE / BASSE TENSION / NIEDERSpannung / BAJA TENSION / BAIXA TENSÃO / LAAGSPANNING / ΧΑΜΗΛΗΣ ΤΑΣΗΣ / NISKIE NAPIĘCIE / НИЗКОЕ НАПРЯЖЕНИЕ / BEZPEČNOST ELEKTRICKÝCH ZAŘÍZENÍ NÍZKÉHO NAPĚTÍ / ALÇAK GERİLİM 2006/95/CEE (EN60335-1 (02)) (e modifichie successive / and subsequent amendments / et modifications successives / und ihren nachfolgende Änderungen / e modificações sucessivas / y modificaciones sucesivas / en daaropvolgende wijzigingen / και επόμενες τροποποιήσεις / z późniejszymi zmianami / с последующими изменениями / s pozdějšími změnami / ve sonraki deęişiklikler).
COMPATIBILITÀ ELETTROMAGNETICA / ELECTROMAGNETIC COMPATIBILITY / COMPATIBILITÉ ÉLECTROMAGNÉTIQUE / ELEKTROMAGNETISCHE COMPATIBILITÄT / COMPATIBILIDAD ELECTROMAGNETICA / COMPATIBILIDADE ELECTROMAGNÉTICA / ELEKTROMAGNETISCHE COMPATIBILITEIT / ΗΛΕΚΤΡΟΜΑΓΝΗΤΙΚΗΣ ΣΥΜΒΑΤΟΤΗΤΑΣ / KOMPATYBILNOŚĆ ELEKTROMAGNETYCZNA / ЭЛЕКТРОМАГНИТНАЯ СОВМЕСТИМОСТЬ / ELEKTROMAGNETICKÁ KOMPATIBILITA / ELEKTROMANYETİK UYUMLULUK 2004/108/CEE (EN61000-6-2, EN61000-6-3) (e modifichie successive / and subsequent amendments / et modifications successives / und ihren nachfolgende Änderungen / e modificações sucessivas / y modificaciones sucesivas / en daaropvolgende wijzigingen / και επόμενες τροποποιήσεις / z późniejszymi zmianami / с последующими изменениями / s pozdějšími změnami / ve sonraki deęişiklikler).

Si dichiara inoltre che è vietata la messa in servizio del prodotto, prima che la macchina in cui sarà incorporato, sia stata dichiarata conforme alle disposizioni della DIRETTIVA MACCHINE. / We also declare that it is forbidden to start the product before the machinery into which it will be incorporated is declared in compliance with the prescriptions of the MACHINERY DIRECTIVE. / Nous déclarons en outre que la mise en service du produit est interdite, avant que la machine où il sera incorporé n'ait été déclarée conforme aux dispositions de la DIRECTIVE MACHINES. / Es wird außerdem erklärt, daß die Inbetriebnahme des Produkts verboten ist, solange die Maschine, in die es eingebaut wird, nicht als mit den Vorschriften der MASCHINEN-DIREKTIVE konform erklärt wurde. / Se declara, además, que está prohibido instalar el producto antes de que la máquina en la que se incorporará haya sido declarada conforme a las disposiciones de la DIRECTIVA MAQUINAS / Verder verklaren wij dat de inbedrijfstelling van het product verboden is, voordat de machine waarin het zal worden opgenomen, conform wordt verklaard aan de beschikkingen van de MACHINERICHTLIJN / Declaramos, além disso, que é proibido instalar o produto, antes que a máquina em que será incorporada, tenha sido declarada conforme às disposições da DIRECTIVA MÁQUINAS / Δηλώνουμε επίσης ότι απαγορεύεται η θέση σε λειτουργία του προϊόντος, πριν το μηχάνημα στο οποίο θα ενσωματωθεί, δηλωθεί ότι συμμορφούται στις διατάξεις της ΟΔΗΓΙΑΣ ΜΗΧΑΝΗΜΑΤΩΝ / Oświadczaamy ponadto, że zabronione jest uruchamianie produktu zanim maszyna, w której zostanie on zamontowany zostanie zadeklarowana jako jako zgodna z zapisami DYREKTYWY MASZYNOWEJ / Помимо этого, мы заявляем, что запрещается ввод в эксплуатацию изделия до тех пор, пока не будет заявлено, что машина, в которую оно будет встроено, соответствует предписаниям ДИРЕКТИВЫ ПО МАШИНАМ. / Kromě toho prohlašujeme, že uvedení výrobku do provozu je zakázáno, dokud stroj, do kterého bude zabudován, nebude mít prohlášení o shodě s předpisy SMĚRNICE O STROJNÍCH ZAŘÍZENÍCH. / Ayrıca ürünü entegre edileceği makinenin, MAKINE DİREKTİFİ'nin hükümlerine uygunluğu beyan edilmeden önce, ürünü hizmete alınmasının yasak olduğu beyan edilir

SCHIO, 12/11/2009

Il Rappresentante Legale / The legal Representative / Le Représentant Légal / Der gesetzliche Vertreter / El Representante Legal / De Wettelijke Vertegenwoordiger / O Representante legal / O Nόμιμος Εκπρόσωπος / Przedstawiciel Prawny / Юридический представитель / Zákonný zástupce / Yasal Temsilci

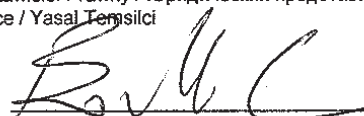

(GIANCARLO BONOLLO)

БЫСТРАЯ УСТАНОВКА

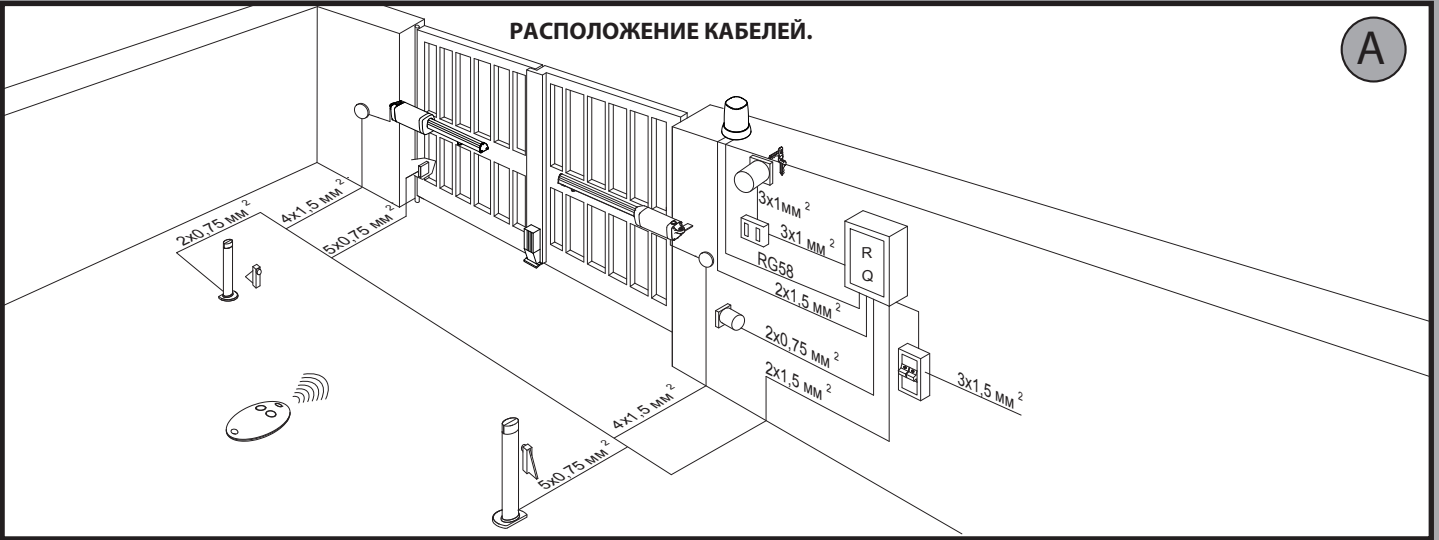
РАСПОЛОЖЕНИЕ КАБЕЛЕЙ.

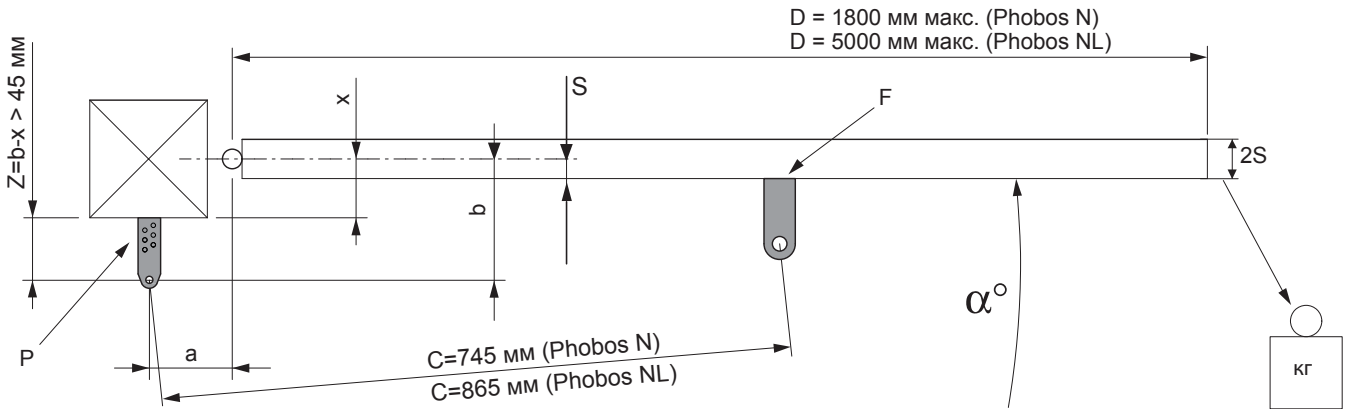

УСТАНОВОЧНЫЕ ПАРАМЕТРЫ.



1

S (mm)	Phobos N		Phobos NL	
	125 кг (~1250 N)	250 кг (~2500 N)	125 кг (~1250 N)	250 кг (~2500 N)
	b (mm)		b (mm)	
20	100 ÷ 120	130 ÷ 210	130 ÷ 160	170 ÷ 260
30	100 ÷ 130	140 ÷ 210	130 ÷ 170	180 ÷ 260
40	100 ÷ 140	150 ÷ 210	130 ÷ 180	190 ÷ 260
50	100 ÷ 150	160 ÷ 210	130 ÷ 190	200 ÷ 260

2 PHOBOS N

b \ a	100	110	120	130	140	150	160	170	180
100					120	116	108	103	99
110					118	110	104	99	96
120					115	105	100	96	93
130				113	107	100	96	92	89
140				111	101	96	92	89	
150			108	104	96	92	88	86	
160			106	97	92	89	85		
170		103	99	92	87	84	82		
180		100	92	87	84	82			
190	100	91	86	83	80				
200	91	85	82	79					
210	85	81	78						α°

3 PHOBOS NL

b \ a	100	110	120	130	140	150	160	170	180	190	200	210	220	230
130	104	107	111	115	116	120	123	125	127	128	128	126	122	116
140	103	107	109	114	115	118	121	124	126	126	126	123	118	114
150	103	106	108	112	114	117	120	122	123	125	125	120	114	111
160	102	105	108	111	112	116	118	121	122	124	123	116	111	106
170	101	105	108	111	111	115	117	120	120	122	118	112	107	
180	101	104	107	109	111	114	116	118	119	118	113	110		
190	100	103	106	108	110	113	115	117	117	115	108			
200	99	103	106	108	109	112	114	115	111	110				
210	99	103	104	107	108	111	112	112	109					
220	99	102	103	107	106	109	110	110						
230	98	101	102	105	106	108	110							
240	98	100	102	105	105	108								
250	98	100	102	106	105									
260	97	100	104	110										α°

КРЕПЛЕНИЕ ЗАДНЕГО КРОНШТЕЙНА НА СТОЛБЕ.

C

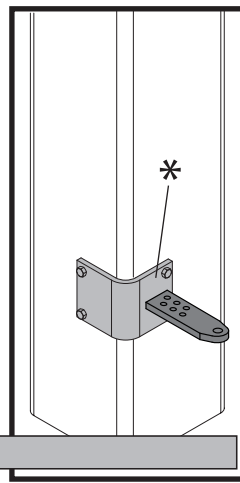
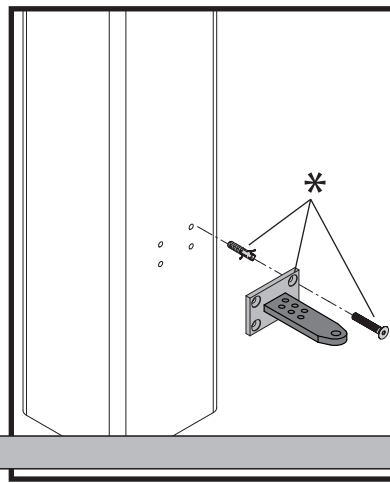
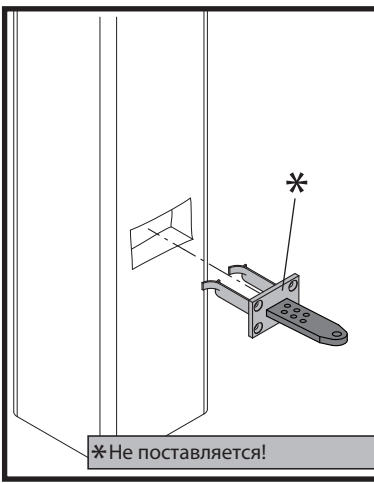
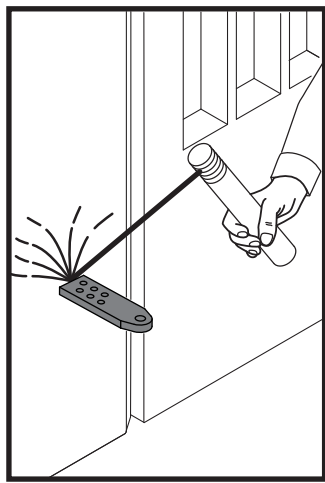

* Не поставляется!

СИЛОВОЙ КАБЕЛЬ.

D

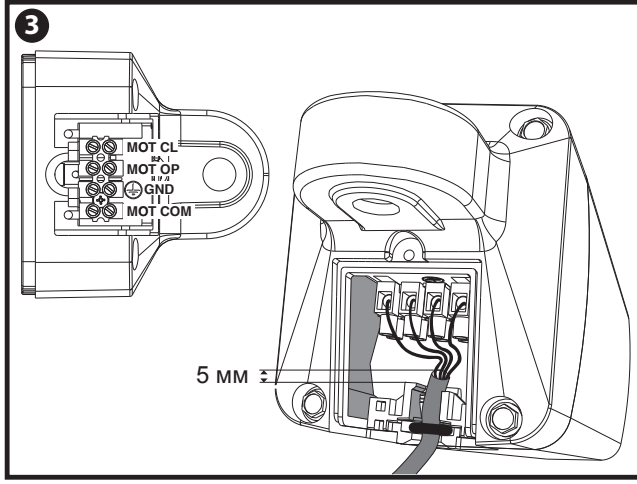
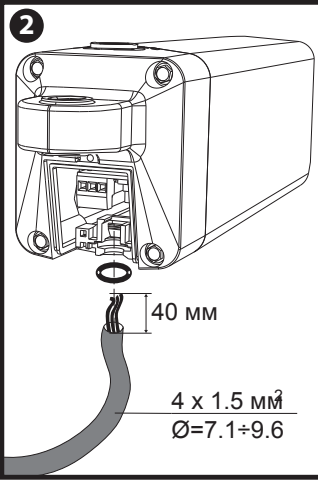
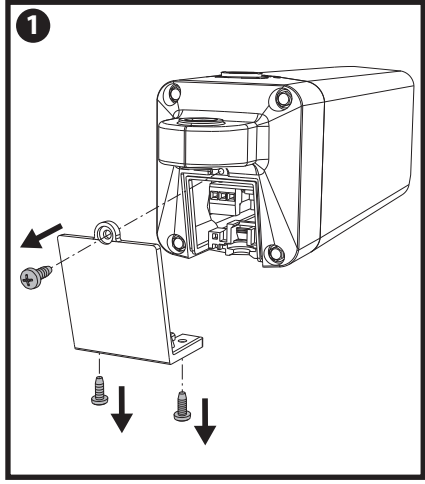

УСТАНОВКА ПРИВОДА НА ЗАДНИЙ КРОНШТЕЙН.

E

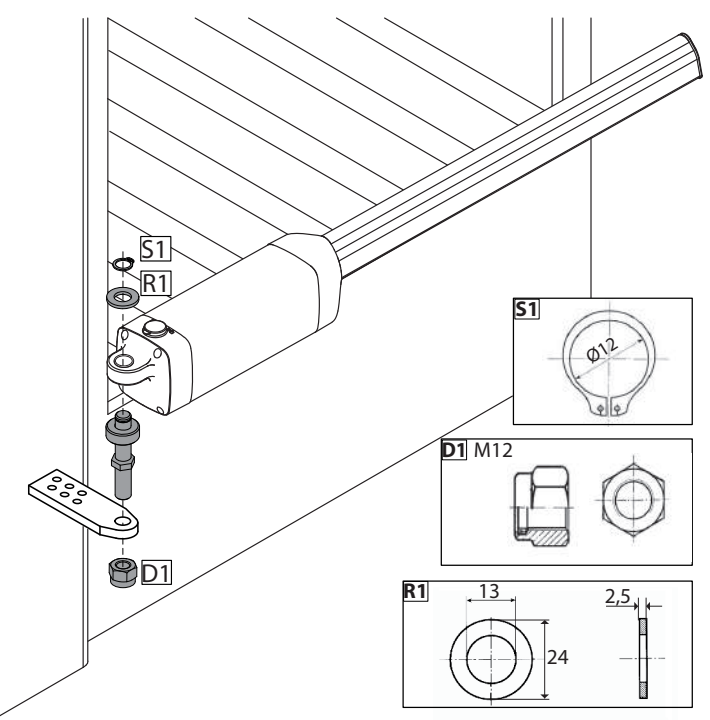

МАКСИМАЛЬНОЕ ОТКЛОНЕНИЕ.

F

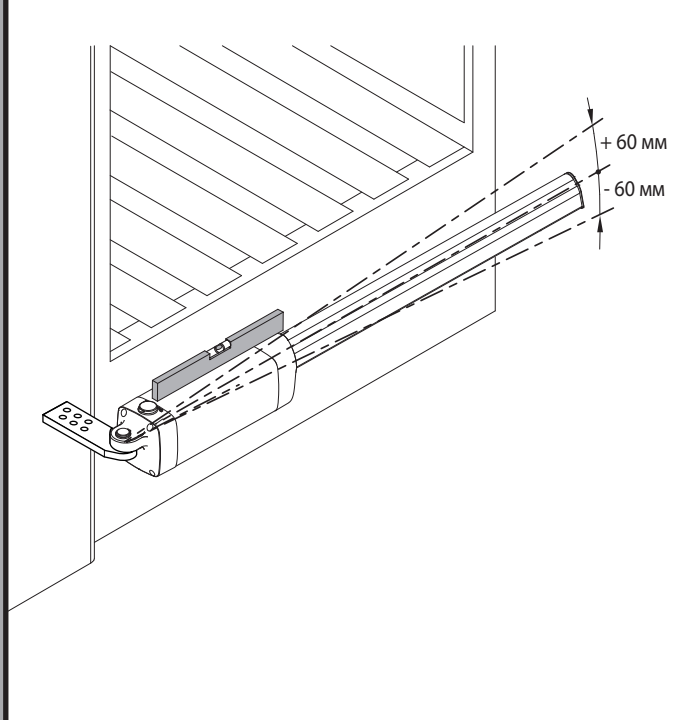

ПРАВИЛЬНАЯ УСТАНОВКА.

G

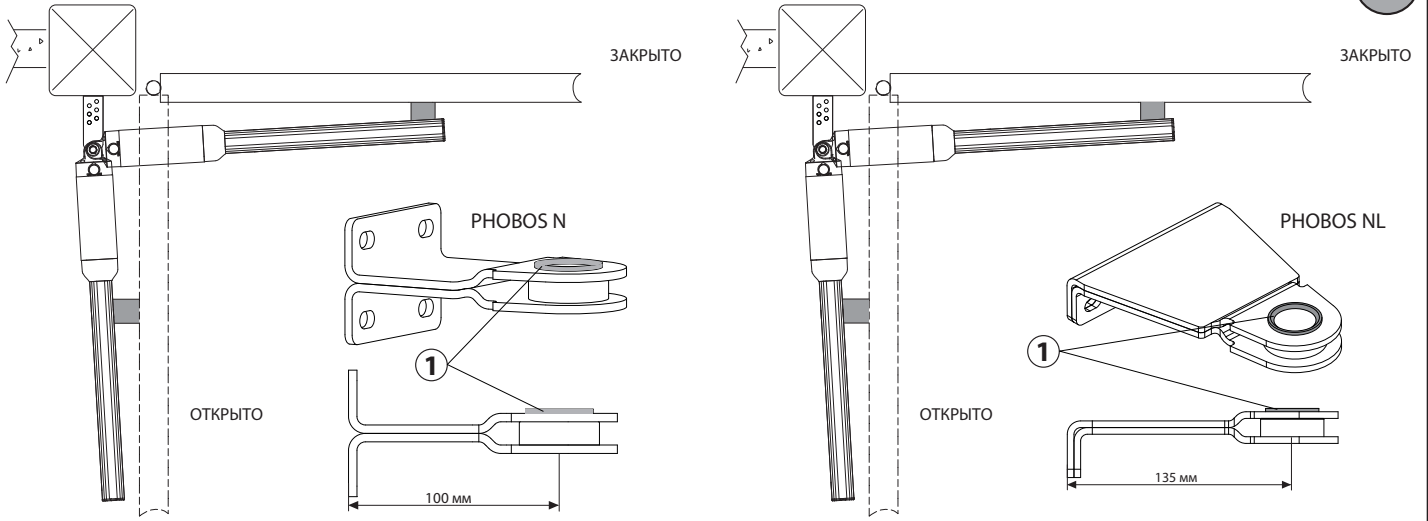

КРЕПЛЕНИЕ ПЕРЕДНЕГО КРОНШТЕЙНА.

H

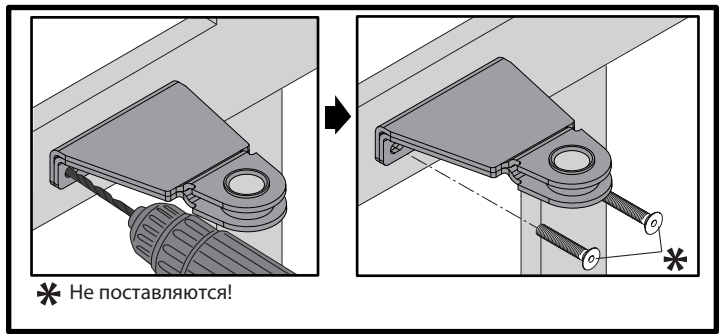
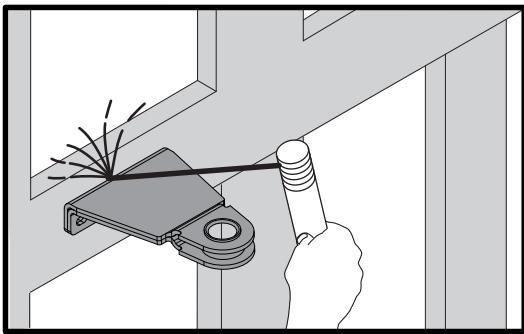

УСТАНОВКА ПРИВОДА НА ПЕРЕДНИЙ КРОНШТЕЙН.

I

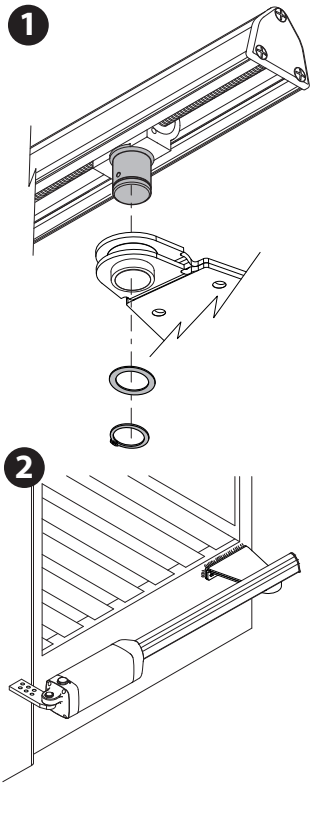

РЕГУЛИРОВКА КОНЦЕВОГО ВЫКЛЮЧАТЕЛЯ ЗАКРЫВАНИЯ.

J

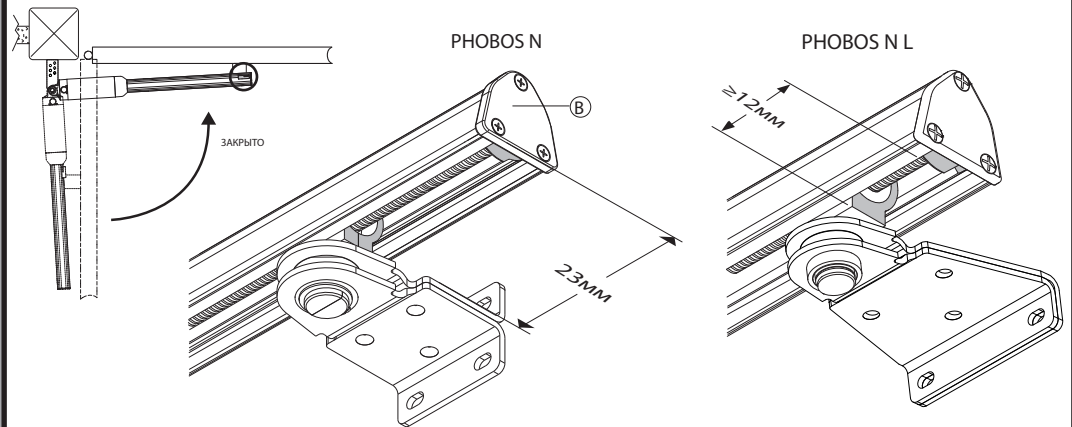

РЕГУЛИРОВКА КОНЦЕВОГО ВЫКЛЮЧАТЕЛЯ ОТКРЫВАНИЯ.

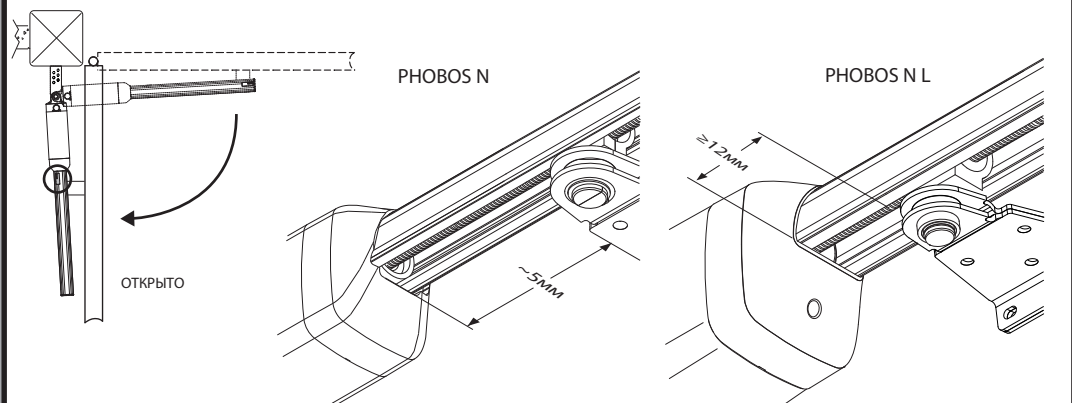

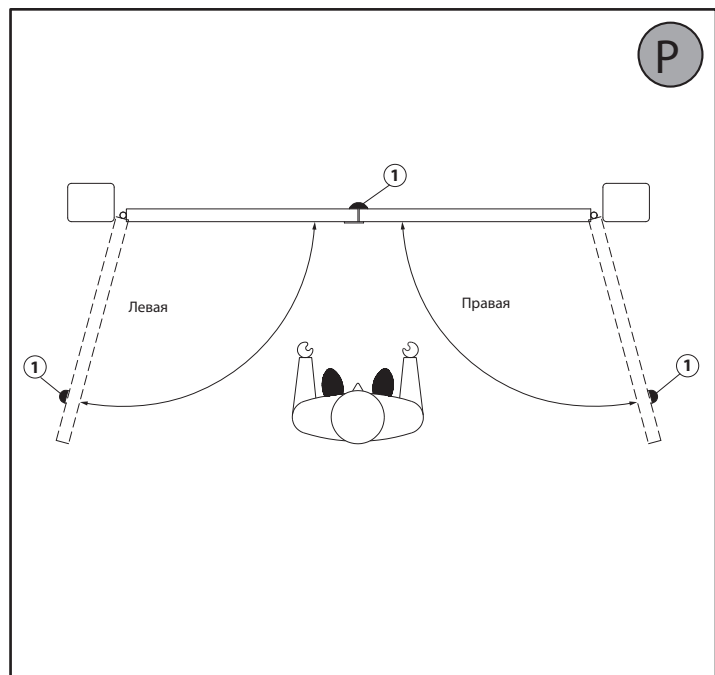
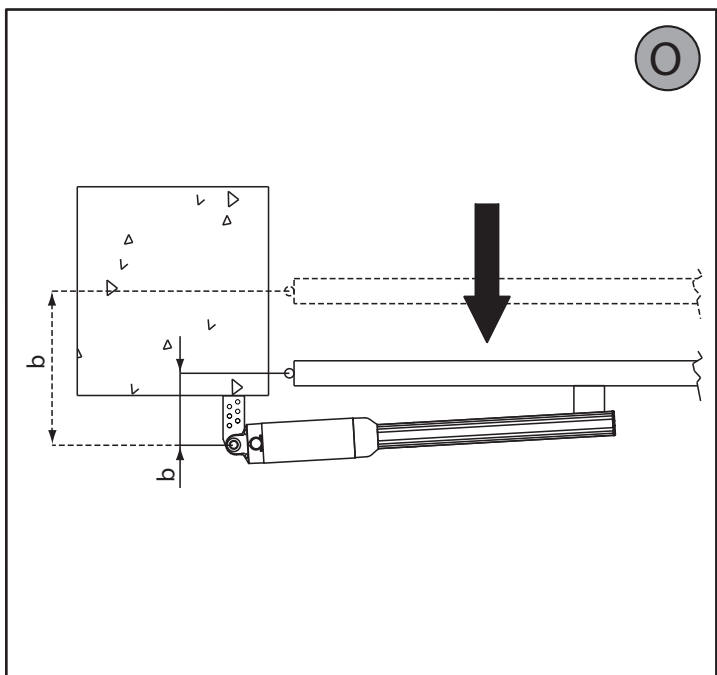
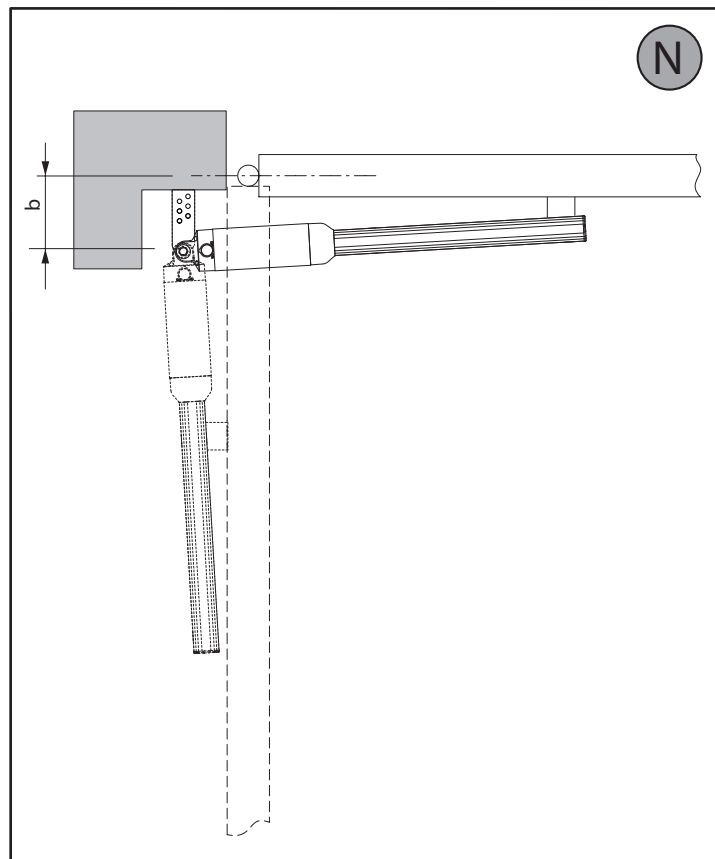
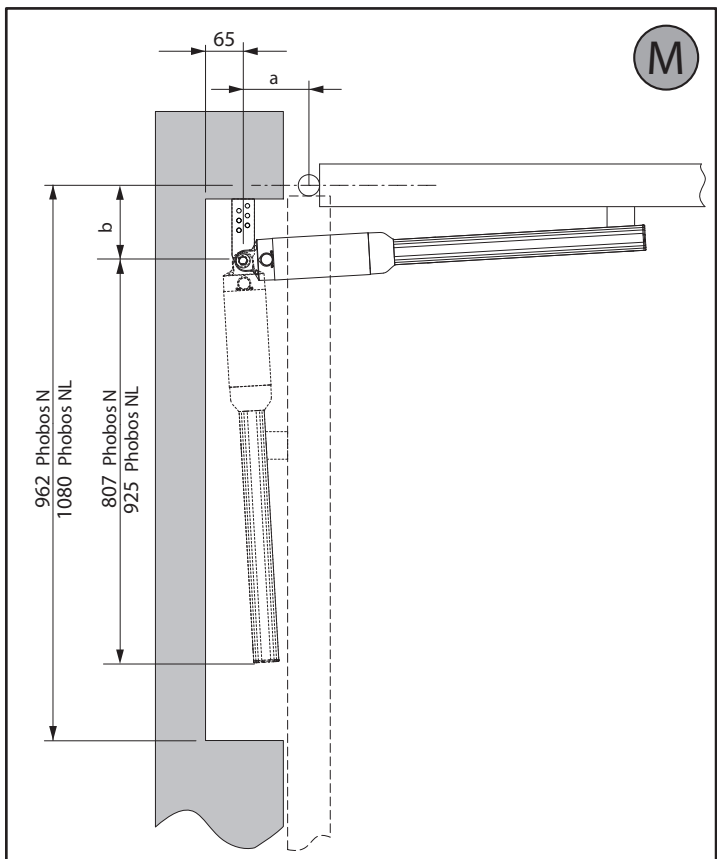
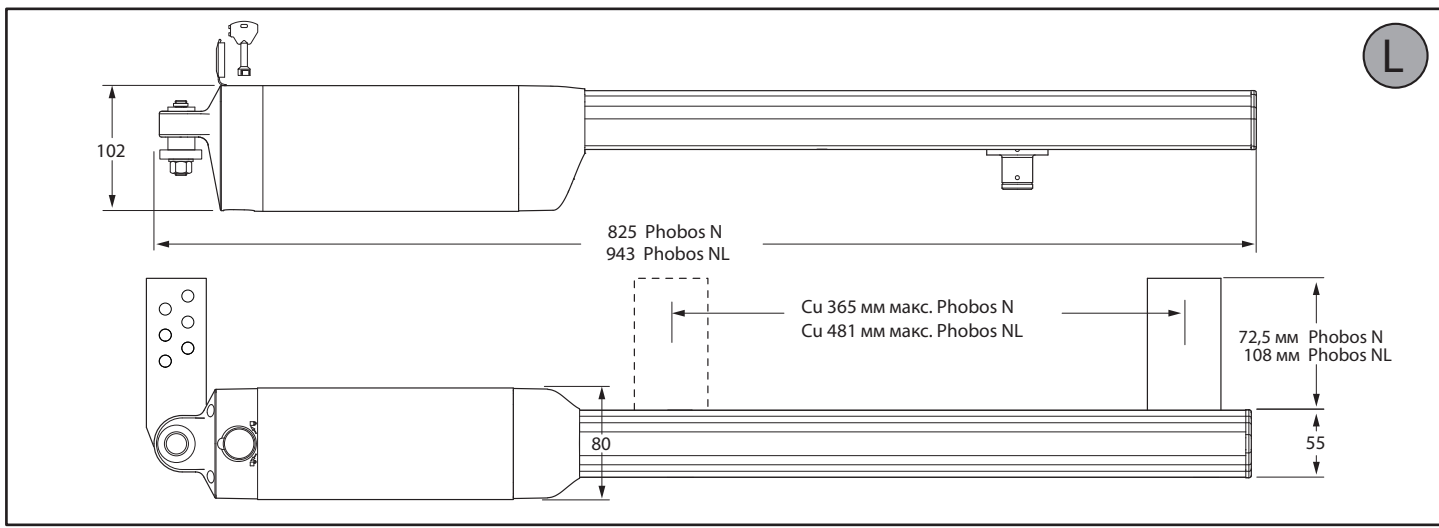

GENERAL WARNINGS

WARNING! Important safety instructions. Carefully read and comply with the Warnings booklet and Instruction booklet that come with the product as incorrect installation can cause injury to people and animals and damage to property. They contain important information regarding safety, installation, use and maintenance.

1) GENERAL SAFETY

WARNING! An incorrect installation or improper use of the product can cause damage to persons, animals or things.

- Scrap packing materials (plastic, cardboard, polystyrene etc) according to the provisions set out by current standards. Keep nylon or polystyrene bags out of children's reach.
- Keep the instructions together with the technical brochure for future reference.
- This product was exclusively designed and manufactured for the use specified in the present documentation. Any other use not specified in this documentation could damage the product and be dangerous.
- The Company declines all responsibility for any consequences resulting from improper use of the product, or use which is different from that expected and specified in the present documentation.
- Do not install the product in explosive atmosphere.
- The construction components of this product must comply with the following European Directives: 2004/108/CEE, 2006/95/EEC, 98/37/EEC and subsequent amendments. As for all non-EEC countries, the above-mentioned standards as well as the current national standards should be respected in order to achieve a good safety level.
- The Company declines all responsibility for any consequences resulting from failure to observe Good Technical Practice when constructing closing structures (door, gates etc.), as well as from any deformation which might occur during use.
- The installation must comply with the provisions set out by the following European Directives: 2004/108/CEE, 2006/95/EEC, 98/37/EEC and subsequent amendments.
- Disconnect the electrical power supply before carrying out any work on the installation. Also disconnect any buffer batteries, if fitted.
- Fit an omnipolar or magnetothermal switch on the mains power supply, having a contact opening distance equal to or greater than 3,5 mm.
- Check that a differential switch with a 0.03A threshold is fitted just before the power supply mains.
- Check that earthing is carried out correctly: connect all metal parts for closure (doors, gates etc.) and all system components provided with an earth terminal.
- Fit all the safety devices (photocells, electric edges etc.) which are needed to protect the area from any danger caused by squashing, conveying and shearing.
- Position at least one luminous signal indication device (blinker) where it can be easily seen, and fix a Warning sign to the structure.
- The Company declines all responsibility with respect to the automation safety and correct operation when other manufacturers' components are used.
- Only use original parts for any maintenance or repair operation.
- Do not modify the automation components, unless explicitly authorised by the company.
- Instruct the product user about the control systems provided and the manual opening operation in case of emergency.
- Anything which is not expressly provided for in the present instructions, is not allowed.
- Check that the stated temperature range is compatible with the place where the operator is to be installed.
- If present, the hold button (hold-to-run control) must be fitted within sight of the door but away from the moving parts, at a height of 1.5 m, and must not be accessible to the public.
- If the operator is fitted at a height lower than 2.5 m, you must guarantee an adequate degree of protection for the electrical and mechanical parts.
- Make sure that squashing is avoided between the moving parts and surrounding fixed parts. Fit all the safety devices (photocells, safety edges etc.) required to protect the area from any danger of squashing, drawing in and shearing.
- After completing the installation, ensure that the motor is set correctly and that the protection and release systems operate correctly.
- Installation must be carried out using the safety devices and controls prescribed by the EN 12978 Standard.

CHECKING INSTALLATION

Before the automated device is finally put into operation, perform the following checks meticulously:

- Make sure all components are fastened securely.
- Check that all safety devices (photocells, pneumatic safety edge, etc.) are working properly.
- Check the emergency operation control device.
- Check opening and closing operations with the control devices applied.
- Check the electronic logic for normal (or personalized) operation in the control panel.

ADJUSTING OPERATING FORCE

WARNING: Check that the force of impact measured at the points provided for by standard EN 12445 is lower than the value laid down by standard EN 12453.

Operating force is adjusted with extreme precision by means of the control unit's electronic control. Operation at the end of travel is adjusted electronically in the control panel.

To provide good anti-crush safety, the operating force must be slightly greater than that required to move the leaf both to close and to open it. Whatever the case, the force, which is measured at the top outer edge of the leaf, must not exceed the limits laid down by the above-mentioned standards.

CONTROL

There are various options when it comes to the control system (manual, remote control, access control with magnetic badge, etc.) depending on the installation's needs and characteristics. See the relevant instructions for the various control system options.

TROUBLESHOOTING

Gearbox malfunctioning

- Use an appropriate instrument to check for voltage across the gearbox motor terminals after giving the opening or closing command. If the motor vibrates but does not rotate, the problem may be:
- Incorrect wiring (see wiring diagram)
- If the leaf moves in the wrong direction, swap over the motor's start connections in the control unit. The first command following a mains power outage should be open STOP LEAVES.

SCRAPPING

Materials must be disposed of in conformity with the current regulations. In case of scrapping, the automation devices do not entail any particular risks or danger. In case of recovered materials, these should be sorted out by type (electrical components, copper, aluminium, plastic etc.).

DISMANTLING

WARNING: before opening the door, the spring must be unloaded (vertical boom). When the automation system is disassembled to be reassembled on another site, proceed as follows:

- Disconnect the power supply and the entire electrical installation.
- Remove the actuator from its fixing base.
- Disassemble all the installation components.
- In the case where some of the components cannot be removed or are damaged, they must be replaced.

Correct controller operation is only ensured when the data contained in the present manual are observed. The Company is not to be held responsible for any damage resulting from failure to observe the installation standards and the instructions contained in the present manual. The descriptions and illustrations contained in the present manual are not binding. The Company reserves the right to make any alterations deemed appropriate for the technical, manufacturing and commercial improvement of the product, while leaving the essential product features unchanged, at any time and without undertaking to update the present publication.

2) ОБЩАЯ ХАРАКТЕРИСТИКА.

Electromechanical operator designed to automate residential-type gates. The gearmotor keeps the gate locked on closing and on opening, without needing an electric lock for leaves up to 3 m long. For leaves ranging between 3m and 5m long, the electric lock becomes indispensable. The operator is provided with an electronic torque limiter. It must be controlled by an electronic control panel provided with torque setting. The end-of-stroke operation is controlled by two magnetic limit devices. The operator is provided with an obstacle detection system complying with EN12453 and EN 12445 standards.

3) ТЕХНИЧЕСКИЕ ХАРАКТЕРИСТИКИ.

PHOBOS N - NL	
Напряжение питания	~230V ±10% 50Гц
Мощность потребляемая	210Вт
Ток потребляемый	0,8А
Класс изоляции	F
Защита температурная	110 °C (самовозврат)
Тяговое усилие	2000N (~200кг)
Скорость	~20мм/с
Реакция на препятствие	Амперстоп в блоке управления
Разблокировка	Ключ CLS
Температура окружающая	-20 °C / + 50 °C
Использование	Полуинтенсивное
Ширина створки макс. без электрозамка	1,8м Phobos N 3м Phobos NL
Ширина створки макс. с электрозамком	3м Phobos N 5м Phobos NL
Вес створки макс.	2500N (~250кг)
Клас защиты	IP X4
Вес привода	50N (~5кг) PHOBOS N 77N (~7,7кг) PHOBOS NL
Размеры	См. Рис. L
Смазка	Консистентная

4) ПРОКЛАДКА КАБЕЛЕЙ Рис. А.

Install the electrical system referring to the standards in force for electrical systems CEI 64-8, IEC 364, harmonization document HD 384 and other national standards.

ВНИМАНИЕ! actuator wiring and accessory connection, refer to the relevant instruction manuals. The control panels and accessories must be suitable for use and conform to current standards.

Should the opening or closing direction be incorrect, it is possible to invert the connections of operation 1 and operation 2 on the control board.

The first command after an interruption of the power supply should be an opening manoeuvre.

5) УСТАНОВОЧНЫЕ ПАРАМЕТРЫ Рис. В.

- P задний кронштейн, крепление к столбу
- F передний кронштейн, крепление к створке
- a/b размеры для определения точки крепления кронштейна "P"
- C размер между осями кронштейнов установки привода
- D ширина створки ворот от оси петли
- x размер от оси створки до края столба
- S половина толщины створки
- Z значение всегда больше на 45мм, чем (b - x)
- кг вес створки максимальный
- α° угол открывания створки

6) РАЗМЕРЫ УСТАНОВКИ КРОНШТЕЙНА НА СТОЛБ Рис. В, поз. 2-3.

6.1) Как пользоваться таблицей?

Select "a" and "b" according to the angle in degrees α° that the gate has to open. The optimum "a" and "b" values for 92° opening at constant speed are highlighted.

If there is too large a difference between "a" and "b", the leaf will not travel smoothly and the pushing or pulling force will fluctuate during its stroke.

To respect the opening speed and ensure the controller operates correctly,

it is best to keep the difference between "a" and "b" as low as possible. The table has been worked out for a 40 mm (PHOBOS NL), 20 mm (PHOBOS N) thick medium-size gate. Always check that there is no possible collision between the gate and the operator.

7) КРЕПЛЕНИЕ КРОНШТЕЙНА НА СТОЛБ Рис. С.

8) СИЛОВОЙ КАБЕЛЬ Рис. D.

The board power supply cable must be of the H 05 RN-F type or equivalent. The equivalent cable must guarantee:

- permanent outside use
- maximum temperature on the cable surface of +50° C
- minimum temperature of -25° C

The wiring of the terminal board must be carried out as shown in Fig. D Ref. 3:

- MOT OP = M 1
- MOT CL = M 2
- ⊕ GND = земля
- MOT COM = N общий

Position the cable sheath so that O ring "K" is inserted in its housing in the base and, leaving the sheath protrude by about J=5 mm (as shown in Fig. D Ref. 3), close the hatch and fix it by means of the 3 screws.

9) УСТАНОВКА ПРИВОДА НА ЗАДНИЙ КРОНШТЕЙН Рис. Е.

10) МАКСИМАЛЬНОЕ ОТКЛОНЕНИЕ Рис. F.

11) ПРАВИЛЬНАЯ УСТАНОВКА Рис. G.

Correct installation entails maintaining a rod stroke margin of approx. 5-10 mm to avoid possible trouble with operation.

12) КРЕПЛЕНИЕ ПЕРЕДНЕГО КРОНШТЕЙНА Рис. H.

ВНИМАНИЕ! the front bracket must be fitted with the bush collar protruding UPWARDS (Fig. G Ref. 1).

13) УСТАНОВКА ПРИВОДА НА ПЕРЕДНИЙ КРОНШТЕЙН Рис. I.

14) ADJUSTMENT OF THE LIMITING DEVICES Fig. J

The correct adjustment of the limiting devices is obtained by setting the working time on the control board correctly. Refer to the instructions of the control board.

WARNING: If the time set on the control unit is insufficient, the leaves might not complete their run.

Slightly increase the working time on the control unit.

15) РАЗМЕРЫ Рис. L.

16) TIPS FOR SPECIAL INSTALLATIONS Fig. M, N, O.

With the leaf fully open, create a recess to accommodate the operator.

Fig. M gives the minimum dimensions of the recess for the various **PHOBOS N - PHOBOS N L** models.

If distance "b" is greater than the values given in the installation tables:

- create a recess in the pillar **Fig. N**
- move the leaf so that it is flush with the pillar **Fig. O**.

17) УСТАНОВКА УПОРОВ.

For the actuator to work properly, it is advisable to use stops "Fig. P Rif. 1" to stop the leaves both when they are open and closed, as illustrated in **Fig. P**. The leaf stops must prevent the actuator rod from reaching the end of its travel.

18) РАЗБЛОКА В АВАРИЙНОЙ СИТУАЦИИ Рис. Y.

19) ЭЛЕКТРОЗАМОК.

ВНИМАНИЕ! В случае ширины створки более 3м, необходимо установить электромагнитный замок.

Для подключения электрозамка требуется дополнительная плата (см. соответствующие инструкции).

ДЕЙСТВИЯ ПОЛЬЗОВАТЕЛЯ В АВАРИЙНОЙ СИТУАЦИИ

Рис. У

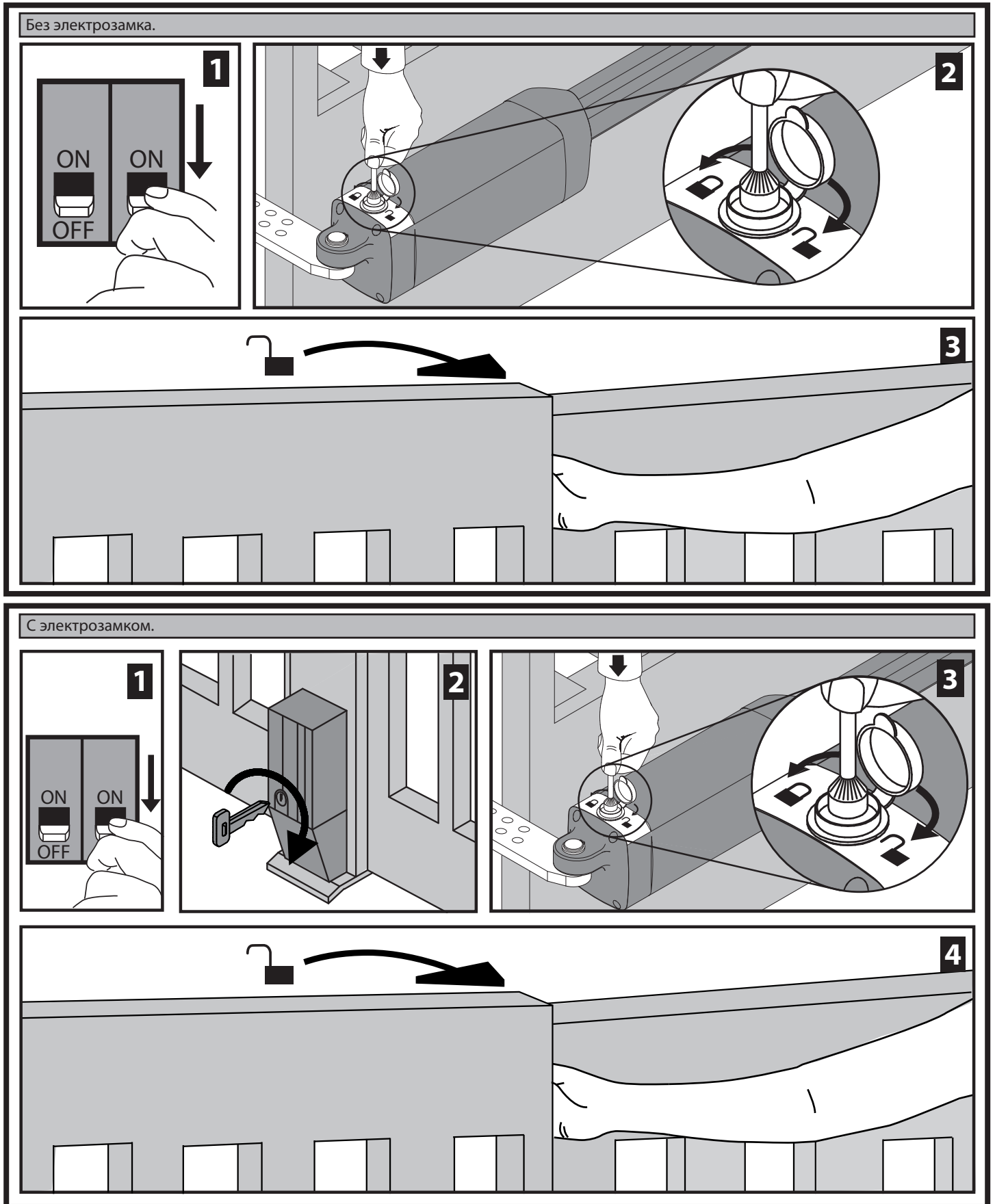

Nel ringraziarVi per la preferenza accordata a questo prodotto, la Ditta è certa che da esso otterrete le prestazioni necessarie al Vostro uso. Leggete attentamente l'opuscolo "AVVERTENZE" ed il "LIBRETTO ISTRUZIONI" che accompagnano questo prodotto in quanto forniscono importanti indicazioni riguardanti la sicurezza, l'installazione, l'uso e la manutenzione. Questo prodotto risponde alle norme riconosciute della tecnica e della disposizioni relative alla sicurezza. Confermiamo che è conforme alle seguenti direttive europee: 2004/108/CEE, 2006/95/CEE, 2006/42/CEE, 99/05/CEE (e loro modifiche successive).

1) SICUREZZA GENERALE

ATTENZIONE **Importanti istruzioni di sicurezza. Leggere e seguire attentamente l'opuscolo Avvertenze ed il Libretto istruzioni che accompagnano il prodotto poiché un uso improprio può causare danni a persone, animali o cose. Conservare le istruzioni per consultazioni future.**

Questo prodotto è stato progettato e costruito esclusivamente per l'utilizzo indicato in questa documentazione. Usi non indicati potrebbero essere fonte di danni al prodotto e fonte di pericolo.

- Gli elementi costruttivi della macchina e l'installazione devono essere in accordo con le seguenti Direttive Europee: 2004/108/CE, 2006/95/CE, 2006/42/CE, 89/106/CE e loro modifiche successive. Per tutti i Paesi extra CEE, oltre alle norme nazionali vigenti, per un buon livello di sicurezza è opportuno rispettare anche le norme citate.
- La Ditta declina qualsiasi responsabilità derivante da un uso improprio o diverso da quello per cui è destinato ed indicato nella presente documentazione nonché dall'inosservanza della Buona Tecnica nella costruzione delle chiusure (porte, cancelli, ecc.) e dalle deformazioni che potrebbero verificarsi durante l'uso.
L'automazione, se installata ed utilizzata correttamente, soddisfa il grado di sicurezza richiesto. Tuttavia è opportuno osservare alcune regole di comportamento per evitare inconvenienti accidentali:
- Tenere bambini, persone e cose fuori dal raggio d'azione dell'automazione, in particolare durante il funzionamento.
- Poiché l'automazione può essere comandata a distanza e quindi non a vista, è indispensabile controllare frequentemente la perfetta efficienza di tutti i dispositivi di sicurezza.
- Quest' applicazione non è destinata all'uso da parte di persone (inclusi i bambini) con ridotte capacità mentali, fisiche e sensoriali, o persone che mancano di conoscenze adeguate, a meno che non siano sotto supervisione o abbiano ricevuto istruzioni d'uso da persone responsabili della loro sicurezza.
- I bambini devono essere controllati affinché non giochino con l'applicazione. Non lasciare radiocomandi o altri dispositivi di comando alla portata dei bambini onde evitare azionamenti involontari.
- Controllare spesso l'impianto, in particolare cavi, molle o supporti per scoprire eventuali sbilanciamenti e segni di usura o danni.
- Per ogni operazione di pulizia esterna o altra manutenzione, togliere l'alimentazione di rete
- Tenere pulite le ottiche delle fotocellule ed i dispositivi di segnalazione luminosa. Controllare che rami ed arbusti non disturbino i dispositivi di sicurezza (fotocellule).
- Non utilizzare l'automatismo se necessita di interventi di riparazione. In caso di malfunzionamento, togliere l'alimentazione, attivare lo sblocco di emergenza per consentire l'accesso e richiedere l'intervento di un tecnico qualificato (installatore professionale).
- Per qualsiasi intervento diretto all'automazione, avvalersi di personale qualificato (installatore professionale).
- Annualmente far controllare l'automazione da personale qualificato.
- Tutto quello che non è espressamente previsto in queste istruzioni, non è permesso.
- Il buon funzionamento dell'operatore è garantito solo se vengono rispettati i dati riportati in questo manuale. La ditta non risponde dei danni causati dall'inosservanza delle norme di installazione e delle indicazioni riportate in questo manuale.
- Le descrizioni e le illustrazioni del presente manuale non sono impegnative. Lasciando inalterate le caratteristiche essenziali del prodotto, la Ditta si riserva di apportare in qualunque momento le modifiche che essa ritiene convenienti per migliorare tecnicamente, costruttivamente e commercialmente il prodotto, senza impegnarsi ad aggiornare la presente pubblicazione.

Thank you for choosing this product. The Firm is confident that its performance will meet your operating needs. Carefully read the "WARNINGS" booklet and "INSTRUCTION BOOKLET" that come with this product as they provide important information regarding safety, installation, use and maintenance. This product meets recognized technical standards and complies with safety provisions. We hereby confirm that it is in conformity with the following European directives: 2004/108/EEC, 2006/95/EEC, 2006/42/EEC, 99/05/EEC (and later amendments).

1) GENERAL SAFETY

WARNING **Important safety instructions. Carefully read and comply with the Warnings booklet and instruction booklet that come with the product as improper use can cause injury to people and animals and damage to property. Keep hold of instructions for future reference.**

This product has been designed and built solely for the purpose indicated herein. Uses not contemplated herein might result in the product being damaged and could be a source of danger.

- The units making up the machine and its installation must meet the requirements of the following European Directives: 2004/108/EC, 2006/95/EC, 2006/42/EC, 89/106/EC and later amendments. For all countries outside the EEC, it is advisable to comply with the standards mentioned, in addition to any national standards in force, to achieve a good level of safety.
- The Firm disclaims all responsibility resulting from improper use or any use other than that for which the product has been designed, as indicated herein, as well as for failure to apply Good Practice in the construction of entry systems (doors, gates, etc.) and for deformation that could occur during use.
If installed and used correctly, the automated system will meet the required level of safety. Nonetheless, it is advisable to observe certain rules of behaviour so that accidental problems can be avoided:
- Keep adults, children and property out of range of the automated system, especially while it is operating.
- As automation can be remotely controlled and therefore not within sight, it is essential to frequently check that all safety devices are perfectly efficient.
- This application is not meant for use by people (including children) with impaired mental, physical or sensory capacities, or people who do not have suitable knowledge, unless they are supervised or have been instructed by people who are responsible for their safety.
- Children must be supervised to ensure they do not play with the application. Keep remote controls or other control devices out of reach of children in order to avoid the automated system being operated inadvertently.
- Check the system frequently, especially cables, springs or supports, to detect any loss of balance and signs of wear or damage.
- When cleaning the outside or performing other maintenance work, always cut off mains power.
- Keep the photocells' optics and illuminating indicator devices clean. Check that no branches or shrubs interfere with the safety devices (photocells).
- Do not use the automated system if it is in need of repair. In the event of a malfunction, cut off the power, activate the emergency release to allow access and call in qualified technical personnel (professional installer).
- If the automated system requires work of any kind, employ the services of qualified personnel (professional installer).
- Have the automated system checked by qualified personnel once a year.
- Anything that is not explicitly provided for in these instructions is not allowed.
- The operator's proper operation can only be guaranteed if the information given herein is complied with. The Firm shall not be answerable for damage caused by failure to comply with the installation rules and instructions featured herein.
- Descriptions and illustrations herein are not binding. While we will not alter the product's essential features, the Firm reserves the right, at any time, to make those changes deemed opportune to improve the product from a technical, design or commercial point of view, and will not be required to update this publication accordingly.

D811521.00100.01



BFT S.P.A.

Via Lago di Vico 44, 36015 Schio (Vi) - **Italy**
tel. +39 0445 69 65 11 / fax. +39 0445 69 65 22
www.bft.it / e-mail: info@bft.it

AUTOMATISMES BFT FRANCE

13 Bdl. E. Michelet, 69008 Lyon - **France**
tel. +33 (0)4 78 76 09 88 - fax +33 (0)4 78 76 92 23
e-mail: contacts@automatismes-bft-france.fr

**BFT Torantriebssysteme GmbH**

Faber-Castell-Straße 29
D - 90522 Oberasbach - **Germany**
tel. +49 (0)911 766 00 90 - fax +49 (0)911 766 00 99
e-mail: service@bft-torantriebe.de

BFT Automation UK Ltd

Unit 8E, Newby Road
Industrial Estate Hazel Grove, Stockport,
Cheshire, SK7 5DA - **UK**
tel. +44 (0) 161 4560456 - fax +44 (0) 161 4569090
e-mail: info@bftautomation.co.uk

BFT BENELUX SA

Parc Industriel 1, Rue du commerce 12
1400 Nivelles - **Belgium**
tel. +32 (0)67 55 02 00 - fax +32 (0)67 55 02 01
e-mail: info@bftbenelux.be

BFT-ADRIA d.o.o.

Obrovac 39
51218 Dražice (Rijeka)
Hrvatska - **Croatia**
tel. +385 (0)51 502 640 - fax +385 (0)51 502 644
e-mail: info@bft.hr

BFT Polska Sp. z o.o.

ul. Kolacińska 35
03-171 Warszawa - **Poland**
tel. +48 22 814 12 22 - fax +48 22 814 39 18
e-mail: biuro@bft.com.pl

BFT USA BFT U.S., Inc.

6100 Broken Sound Pkwy. N.W., Suite 14
Boca Raton, FL 33487 - **U.S.A.**
T: +1 561.995.8155 - F: +1 561.995.8160
TOLL FREE 1.877.995.8155 - info.bft@bft-usa.com

BFT GROUP ITALIBERICA DE AUTOMATISMOS S.L.

Pol. Palou Nord,
Sector F - C/Cami - Can Basa nº 6-8 08401 Granollers -
(Barcelona) - Spain
tel. +34 938 61 48 28 - fax +34 938 70 03 94
e-mail: bftbcn@bftautomatismos.com

Pl. Comendador - C/
informática, Nave 22 - 19200 Azuqueca de henares
(Guadalajara) - Spain
tel. +34 949 26 32 00 - fax +34 949 26 24 51
e-mail: administracion@bftautomatismos.com

BFT SA-COMERCIO DE AUTOMATISMOS E MATERIAL DE SEGURANÇA
Urbanizaçao da Pedrulha Lote 9 - Apartado 8123,
3020-305 COIMBRA - **PORTUGAL**
tel. +351 239 082 790 - fax +351 239 082 799
e-mail: geral@bftportugal.com